

NOTES:

1. PIPE MATERIAL MAY INCLUDE REINFORCED CONCRETE PIPE (RCP) OR HIGH DENSITY POLYETHYLENE (HDPE) AS DETERMINED BY THE DISTRICT. THE LONGITUDINAL SLOPE FROM THE ENTRANCE PAVEMENT TO THE TOP OF THE PIPE SHALL BE 6:1.

2. WHEN A BITUMINOUS CONCRETE (ASPHALT) PAVEMENT SECTION IS PROPOSED, THE EXISTING FRONTAGE ROAD PAVEMENT SHALL BE SAWCUT 1'-0" INSIDE THE EDGE OF PAVEMENT. THE TIE-IN SHALL BE DONE PER THE ASPHALT PAVEMENT TIE-IN DETAIL AS SHOWN.

3. ENTRANCE DESIGNED FOR A P/B DESIGN VEHICLE.

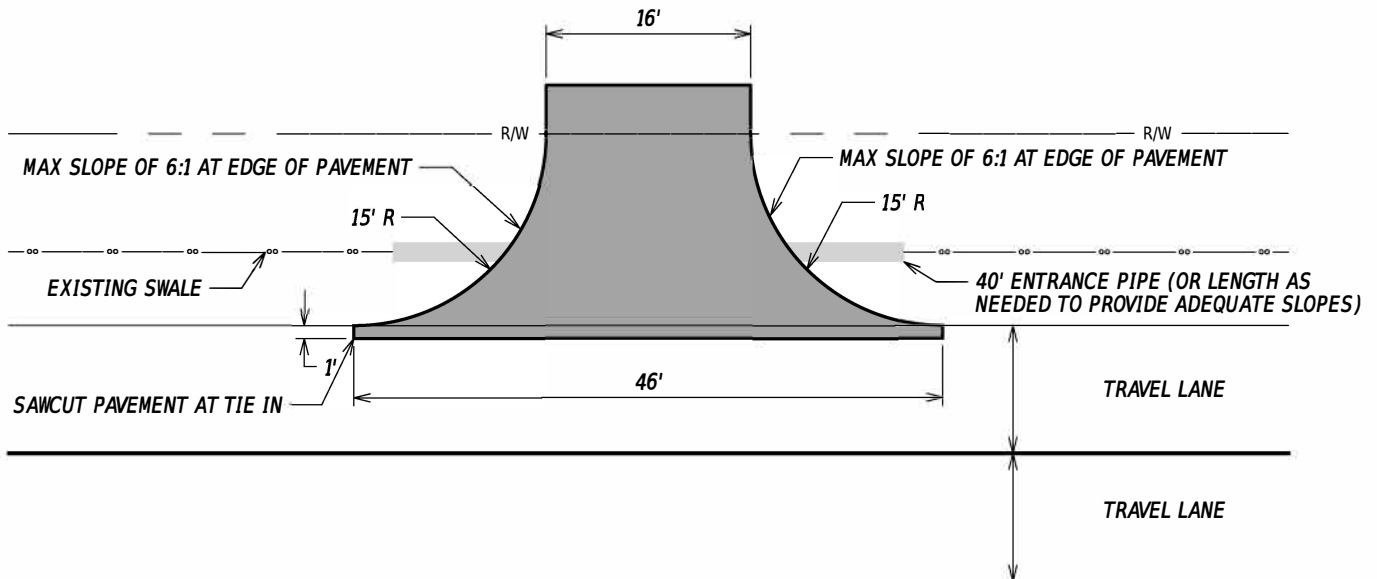
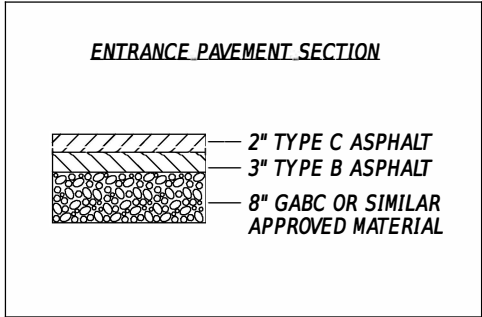

SOLAR FARM ENTRANCE PLAN